

# Introducing NZ's First Fully Retractable Louvres: The Concertina

For more info visit  
[JohnsonAndCouzins.co.nz](http://JohnsonAndCouzins.co.nz)



New Zealand's roof louvre market has been revolutionised! Johnson & Couzins are proud to present **NZ's first retractable louvres!** Designed and manufactured in NZ, the **Concertina Louvre** introduces a unique 'slideaway' technology. At the touch of a button your louvered roof parts and slides back to reveal a starry sky or the warming sun, adding value and style to any outdoor area.



## Retracted Louvres

The **Concertina Louvre** slides from the centre out to both ends. Its louvre fins stack away neatly, leaving 80% clear space.

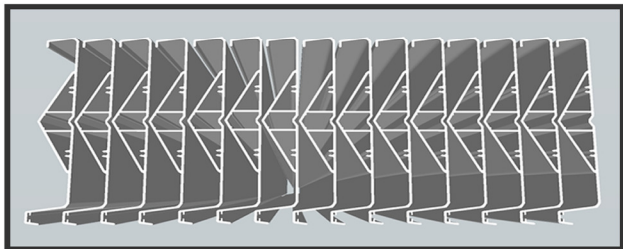
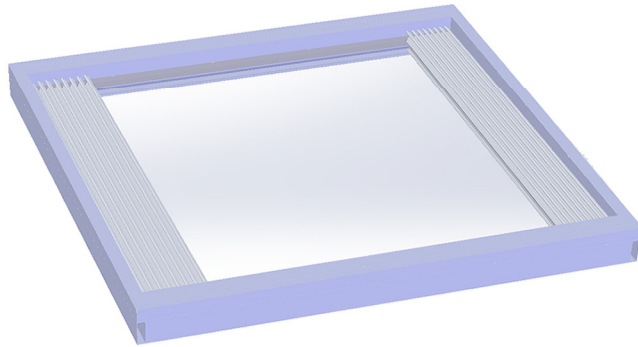

## Open Louvres

The **Concertina Louvre** rotates through 90 degrees, allowing for total control of light, shade and ventilation.

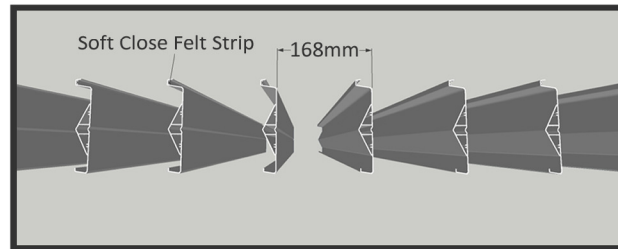
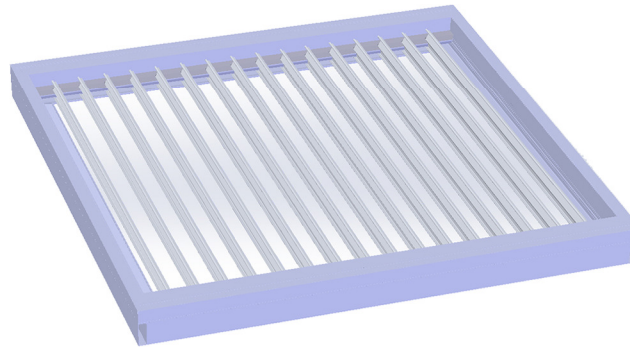

## Closed Louvres

The **Concertina** is designed to be entirely weather-tight when closed. The louvre fins create a flat tongue-and-groove finish.

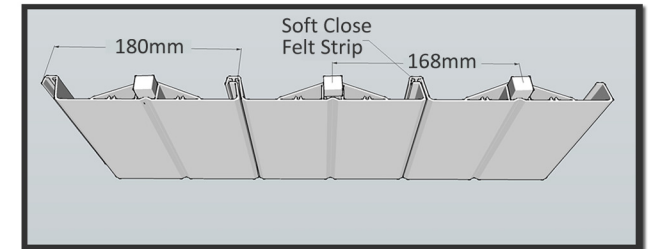
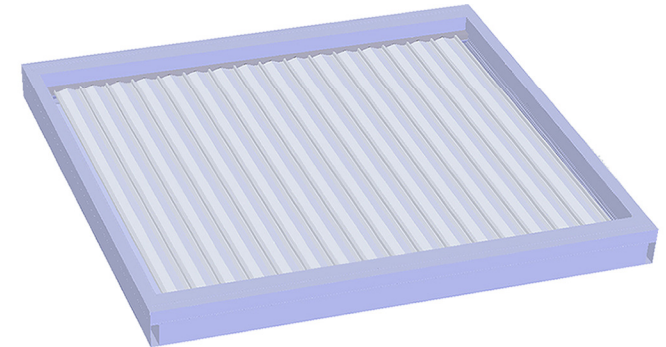

# The Concertina Louvre at a Glance

For more info visit  
[JohnsonAndCouzins.co.nz](http://www.JohnsonAndCouzins.co.nz)



- Designed and manufactured in New Zealand by Johnson & Couzins.
- The Concertina Louvre fins rotate from fully closed to vertical, transforming a flat weather-tight roof to a traditional louvre roof. The fins then part in the centre and neatly stack at both ends, leaving 80% clear space.
- Fins span up to 4.5 m in a medium wind load.
- The entire operating system is concealed to create a streamlined and uncluttered finish.
- For all technical information and downloadable content for the Concertina Louvre or any of our other great outdoor shade products, please visit [www.JohnsonAndCouzins.co.nz](http://www.JohnsonAndCouzins.co.nz).



## Standard Profile Overview

We have designed the Concertina Louvre with a focus on longevity, style and serviceability. The Concertina Louvre has the same great fin model as our current Silencio Louvre Roof, with flat modern lines, wide spans and soft-close surfaces. As with the popular Silencio, design is all-important. Therefore, no moving parts (except the fins) are visible (even from the top), and the louvre's sleek lines won't be interrupted by motor housings.

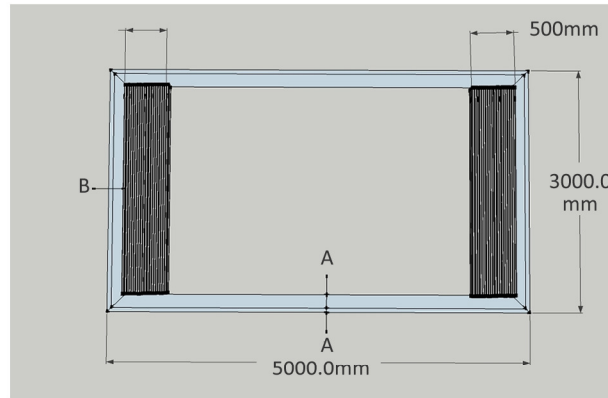

*Concertina Louvre*

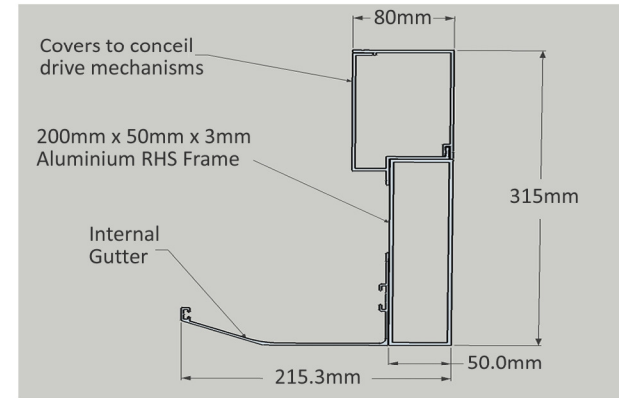

*Section B-B (from the end)*

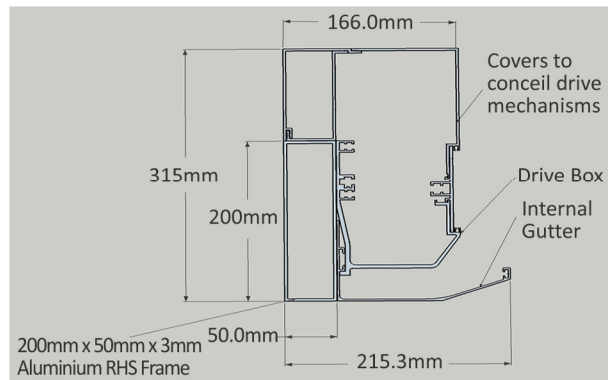

*Section A-A (from the side)*

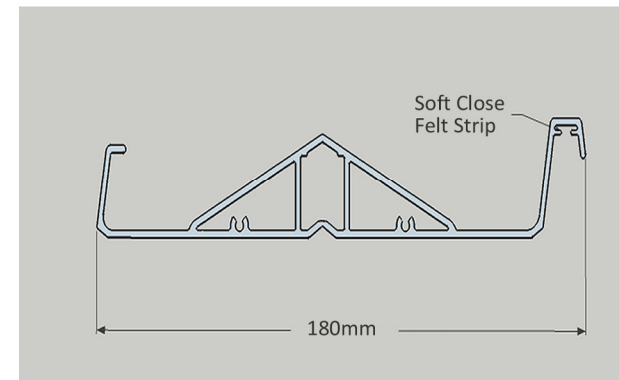

*Louvre Fin Profile*

# Johnson & Couzins' Concertina Louvre



PHONE 03 318 6804  
 MOBILE 021 777 993  
 EMAIL [sam.richards@rcengineers.co.nz](mailto:sam.richards@rcengineers.co.nz)  
 1365 Leaches Road  
 RD2 Darfield 7572



For more info visit  
[JohnsonAndCouzins.co.nz](http://JohnsonAndCouzins.co.nz)



## Revised Structural Tables 9426 September 2012

### 1. JOHNSON & COUZINS LOUVRE SYSTEM

Johnson & Couzins have developed an opening louvre system primarily for use in Greater Christchurch and Auckland areas. The system is manufactured out of aluminium and consists of a perimeter 250 x 50 x 3 RHS frame with either a heavy or light-grade louvre spanning in one direction, loading up one of the frame members. The louvre roof is typically supported on SHS posts and braced against the existing structures. Maximum spans for the perimeter beams and louvres are set out in tables 3.1 & 4.1 below.

### 2. DESIGN SCOPE

Richards Consulting Engineers have designed and presented maximum spans for specific wind loadings as per the design parameters outlined below. The design of the structure is in compliance with the New Zealand Building Code (NZBC) section B1. The attached Producer Statement covers the maximum spans only and excludes connections, lateral support.

#### 2.1. DESIGN SCOPE

The tables presented below apply to louvres within the following limits:

- The louvre frame is braced laterally
- The louvre roof will not be easily accessed i.e. adjacent to a deck
- The site wind speed needs to be determined before designing louvre system
- Located in areas with design snow loads lower than 0.9kPa
- Positioned with at least one edge adjacent to a building that is higher than the louvres
- Louvres installed horizontally
- Areas considered sensitive to deflections should be specifically designed

Dynamic performance has not been assessed and relies on the proven in-service performance to date.

#### 2.2. DESIGN LOADINGS

The member tables have been designed to withstand the following loadings:

Wind – 37m/s and 44m/s design wind speed

Earthquake – Exclude from scope as lateral resistance of frame assumed

Snow – 0.9kPa open ground snow load (equivalent of up to 100m altitude in Canterbury region)

Live load – Roof load - 0.25kPa and 1.1kN point load on louvres shared between two louvres (treated as a cladding) and 1.4kN point load for perimeter beam

#### 2.3. SERVICEABILITY CRITERIA

A maximum deflection of 60mm has been designed for as requested by Johnson & Couzins. This limit should be reconsidered where the environment is sensitive to deflections.

### 2.4. MATERIAL AND SECTION PROPERTIES

Louvres are made from aluminium with a 6060 alloy and a T5 temper. Structural members as follows:

Light louvre  $I_x = .05318 \times 10^6 \text{mm}^4$

Heavy louvre  $I_x = 1059.0 \times 10^6 \text{mm}^4$

### 2.5. DURABILITY

Aluminium provides adequate durability for the life of the structure (50 years) as outlined in E1/AS2.

### 2.6. REFERENCES

The following documents were referenced for the design:

- AS/NZS 1170 – Design actions
- AS/NZS 1664.1: 1997
- Section data provided by Johnson & Couzins

### 3. LOUVRE

Table 3.1 – Johnson & Couzins Maximum Louvre Spans

Louvre	Medium Wind Zone (37m/s)	High Wind Zone (44m/s)
Light	3.4m	3.0m
Heavy	4.4m	4.0m

Notes:

1. Includes allowance to resist 0.9kpa open ground snow load.
2. Site wind speed to be verified by others.
3. Numbers in brackets are deflections experienced for the spans specified.

### 4. PERIMETER FRAME BEAM

Table 4.1 – Johnson & Couzins Maximum Perimeter Beam (200 x 50 x 3 RHS) Spans

Beam Location	Medium Wind Zone (37m/s)		High Wind Zone (44m/s)	
	Light Louvre	Heavy Louvre	Light Louvre	Heavy Louvre
Perimeter	6.0m	5.7m	5.6m	5.4m
Central	5.0m	4.7m	4.8m	4.5m

Notes:

1. Includes allowance to resist 0.9kpa open ground snow load.
2. Site wind speed to be verified by others.
3. Perimeter beam supports half louvre span.
4. Central beam supports louvres on both sides.
5. Spans calculated from rely on correct selection of louvre.
6. A deflection limit of 60mm has been used. Protected areas sensitive to deflections should consider specific design.